



WINDSTRONG®
WINDLOCKED ROLLER DOORS
Regions C & D To Meet AS/NZ 4505:2012



WINDSTRONG® Windlocked Roller Door

In May 2013 the National Construction Code was changed to include reference to AS/NZS 4505:2012 Garage doors and other large access doors (up to 3m high) with specific focus on new construction in **Regions C and D**. The relevant wind pressure for doors higher than 3m can still be computed by referring to AS/NZS 1170.2 or AS 4055.

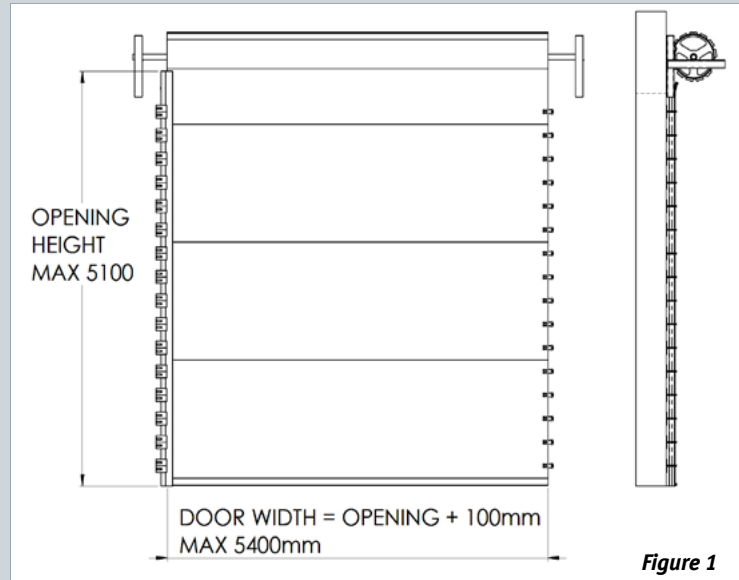

Figure 1

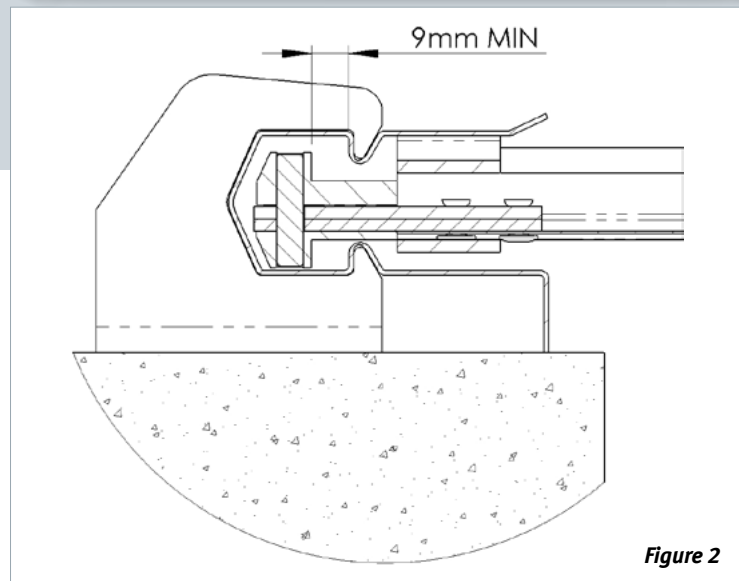

Figure 2

This update covers possible door solutions for using the Taurean **WINDSTRONG®** Windlocked Roller Door. The ultimate wind pressure capacities and the magnitude of the design forces transferred to the supporting structure are given, which both vary with the door width.

The information is based on static and cyclic testing conducted according to AS/NZS 4505:2012.

Taurean Door Systems comply with all requirements contained in AS/NZS 4505:2012.

Note: Data subject to change because of ongoing testing.

See www.taureands.com.au/windratings for latest information.

The **WINDSTRONG®** Windlock Roller Door has a riveted wind-clip at every second flat, at a spacing of 7 clips/m each side. Every wind-clip is supported by two steel track brackets. It is classified for use both as a Domestic door in Class 1 and 10 buildings to 20,000 cycles, and as a General Purpose – Medium Cycle door in Class 1 to 10 buildings to 20,000 cycles also.

MAX ULTIMATE DESIGN WIND PRESSURE

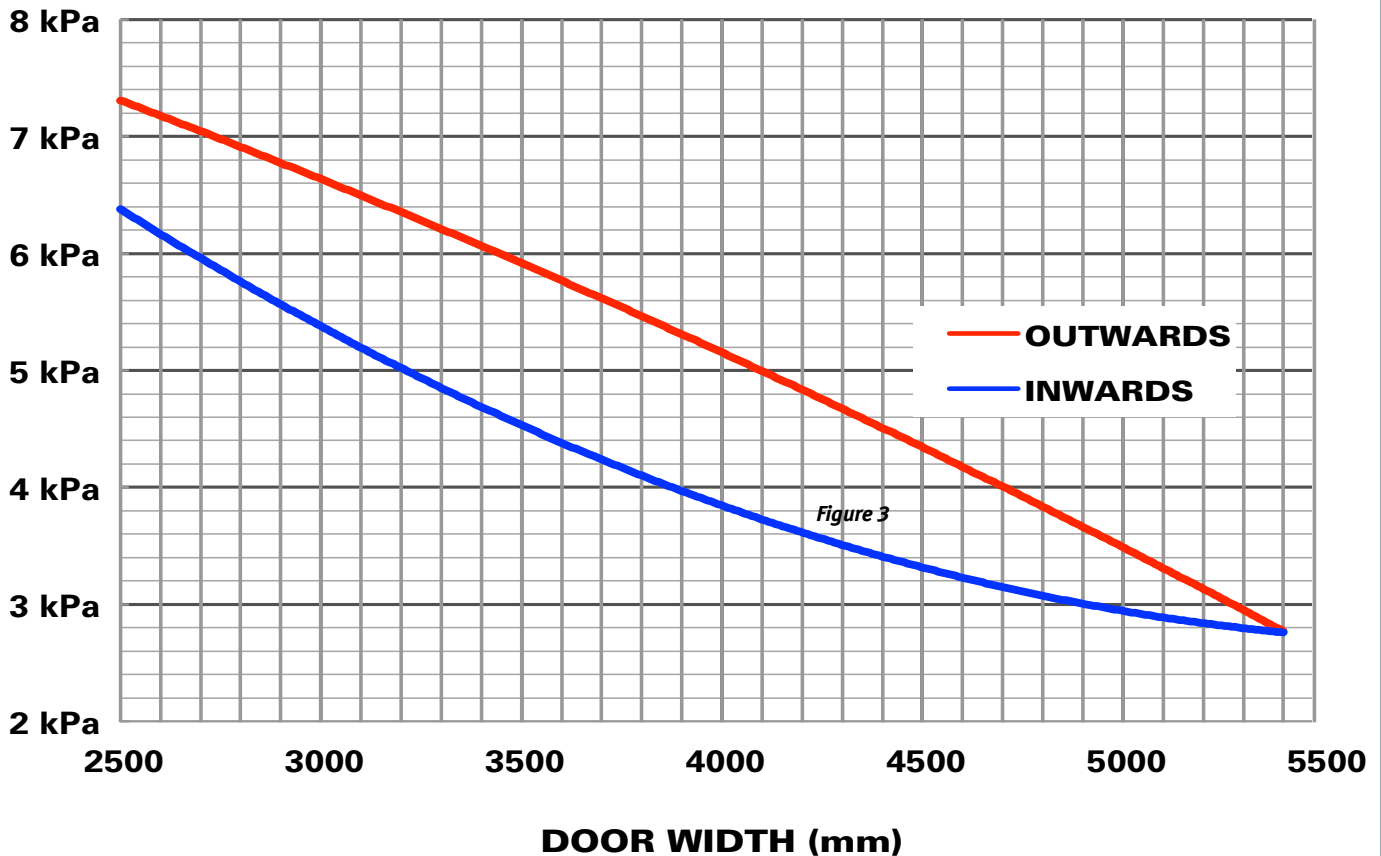

Design capacity of WINDSTRONG® Doors

WINDSTRONG® doors are rated to the pressures in Figure 3 when installed as per instructions published by Taurean Door Systems. For Ultimate Design Pressure Rating the lower pressure curve (usually inwards) is used. Maximum width doors for a given Domestic Cyclonic Wind Classification are in Table 1.

MAXIMUM DOOR WIDTH FOR EACH CYCLONIC WIND CLASSIFICATION FOR DOMESTIC (CLASS 1 and 10) BUILDINGS

Wind classification	Ultimate design wind pressure (kPa)		Max door width	Max Force F_x^*
	Inward	Outward		
C1	1.96	2.04	5400 mm	28.0 kN/m
C2	2.92	3.04	5050 mm	32.8 kN/m
C3	4.30	4.95	3660 mm	34.4 kN/m
C4	5.81	6.69	2770 mm	34.1 kN/m

Table 1

MAXIMUM ULTIMATE WIND PRESSURE AND CORRESPONDING FORCES FOR GENERAL PURPOSE (CLASS 1 to 10) BUILDINGS

Door width (mm)	Maximum ultimate wind pressure (kPa)		Maximum ultimate forces on door frame (kN/m)
	Inward	Outward	
2550	6.27	7.24	33.8
2800	5.76	6.91	34.9
3100	5.20	6.50	36.2
3430	4.64	6.02	37.1
3750	4.17	5.54	37.7
4350	3.46	4.59	37.0
5100	2.89	3.31	33.6
5400	2.76	2.77	33.9

Table 2

Alternatively, interpolate between lines of Table 2 to find maximum ultimate design wind pressures and maximum abutment forces of other sizes and General Purpose doors. Table 2 gives the forces and ratings of the upper size of the widths from the Taurean Door Systems price list. **Note: Ultimate Wind Pressures in Table 2 may be higher than Wind Classification Pressures available in Table 1 for a particular width.**

*Forces Transmitted To Structure

MAXIMUM CATENARY FORCES ON DOOR FRAME GENERAL PURPOSE (CLASS 1 to 10) BUILDINGS

Ultimate Pressure (kPa)	Forces (kN/m) for Door width (mm)							
	2550	2800	3100	3430	3750	4350	5100	5400
2.0	14.3	15.3	16.4	17.7	18.9	22.1	26.6	28.3
2.4	16.4	17.5	18.8	20.3	21.8	25.2	29.7	31.5
2.8	18.3	20.0	21.2	22.9	24.5	28.0	32.4	
3.2	20.2	21.6	23.4	25.3	27.2	30.5		
3.6	21.9	23.5	25.5	27.6	29.7			
4.0	23.5	25.3	27.5	29.8	32.1			
4.4	25.1	27.0	29.3	31.9				
4.8	26.5	28.6	31.1					
5.2	27.8	30.1	32.8					
5.6	29.0	31.4						
6.0	30.2							

Table 3

MAX CATENARY FORCES for C1-C4 DOMESTIC BUILDINGS CLASS 1 and 10

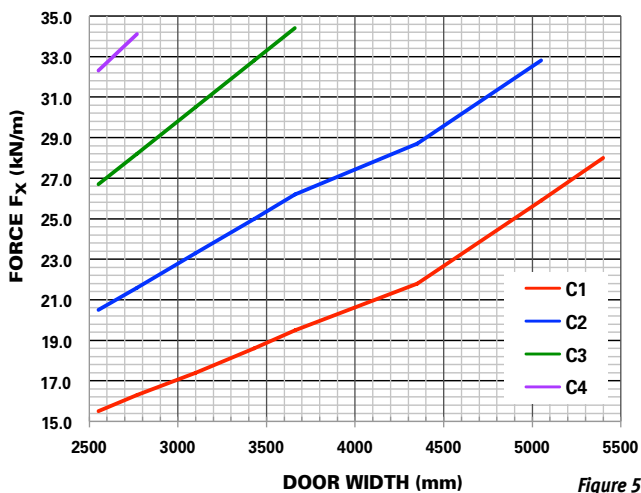

Figure 5

Designers must allow for the forces that a **WINDSTRONG®** door transmits to the supporting structure when subject to a wind pressure. The forces have two components, one aligned with the wind direction F_Y and another parallel with the door plane due to catenary tension in the door curtain F_X .

The designer can calculate the force F_Y using: $F_Y = \frac{wL}{2}$

Where:

- F_Y = force per vertical meter (kN/m)
- w = ultimate wind pressure (kPa) • L = door width (m)



Figure 4

The maximum catenary force F_X can then found by referencing Figure 5 for Domestic, or Table 3 for General Purpose doors.

Figure 5 gives the maximum catenary F_x forces at various pressures. For pressures lower than the ultimate design wind pressure the forces will be lower. Interpolate from Table 3 for general solutions. Maximum pressure (usually outwards) is used to determine the force. **Note: Interpolation (but not extrapolation) is allowed for all tables and graphs presented here. For doors <2550mm wide assume values for wind pressure capacity and abutment forces to be as per an equivalent 2550mm door application.**

IMPORTANT NOTICE AND DISCLAIMER The information contained within this brochure is intended for general use and information only. Before application in a particular situation, Stramit recommends that you obtain appropriate independent qualified expert advice confirming the suitability of product(s) and information in question for the application proposed. While Stramit accepts its legal obligations, be aware however that to the extent permitted by law, Stramit disclaims all liability (including liability for negligence) for all loss and damage resulting from the direct or indirect use, or reliance on, the information provided in this brochure.

Taurean Door Systems Unit 3/1464 Ferntree Gully Road, Knoxfield, Victoria 3180 Ph: +613 9721 8366

© 2013 Stramit Corporation Pty Limited ABN 57 005 010 195 A member of the Fletcher Building Group.

™ and © are trademarks of Stramit Corporation Pty Limited trading as Taurean Door Systems.

